

**TOWN OF NEW CASTLE, COLORADO  
ORDINANCE 2011-4**

AN ORDINANCE OF THE NEW CASTLE TOWN COUNCIL  
AMENDING THE MUNICIPAL CODE CONCERNING THE ADOPTION OF  
A NEW SIGN CODE.

WHEREAS, the Town's existing sign code was outdated and difficult to implement; and

WHEREAS, the Planning and Zoning Commission and Town Staff have conducted extensive research into the needs, wants, and requirements of the Town concerning the location, placement and dimensional requirements for signage; and

WHEREAS, pursuant to section 17.92.030(B) of the New Castle Municipal Code the Planning Commission held a public hearing on January 26, 2011 to consider amending the municipal code to adopt a new sign code; and

WHEREAS, the Planning Commission adopted Resolution PZ 2011-1 recommending that the Council approve the adoption of a new sign code; and

WHEREAS, in Resolution PZ 2011-1 the Planning and Zoning Commission found as follows:

- A. That signs are a necessary means of visual communication for the convenience of the public;
- B. That the Town has legitimate interest in using its police powers to regulate signs to promote aesthetic goals, protect the public against visual clutter, protect the public, including motor vehicle users, against damage or injury caused by signs that serve as a distraction or that are poorly constructed or maintained, and to promote signs that contribute in a positive way towards the ordered growth and development of the Town.
- C. A sign code should recognize the specific and diverse needs of the public, business, and non-profit/charitable communities, and recognize the varying needs of certain areas of the Town including historic preservation, industrial and commercial areas, gateway areas, and residential areas.
- D. The Town has repeatedly expressed its commitment to the conservation of natural resources, including having a Climate Action Advisory Committee and being a signatory to the U.S. Conference of Mayors Climate Protection Agreement, and the Town believes a sign code should be designed to promote the Town's goals of energy conservation and the use of renewable and reusable resources.
- E. That a sign code should be user-friendly and accessible to the general public.

WHEREAS, the Town desires to consider amendments to the New Castle Municipal Code to repeal the existing sign code and replace it with a new sign code; and

WHEREAS, the Town Council hereby makes the same findings as the Planning Commission, detailed above, and hereby approves the changes to the land use code as set forth below.

NOW, THEREFORE, BE IT ORDAINED BY THE TOWN COUNCIL OF THE TOWN OF NEW CASTLE, COLORADO:

1. Recitals. The foregoing recitals are incorporated herein as findings and determinations of the New Castle Town Council.

2. Amendment. The Town Council hereby repeals and reenacts the following sections of Town of New Castle Municipal Code as follows:

A. Chapter 15.32 of the New Castle Municipal Code is hereby repealed in its entirety.

B. Section 17.04.040 of the New Castle Municipal Code is hereby amended as follows:

“Sign” means as defined in ~~Section 15.32.010~~ Chapter 17.18.

C. Section 17.40.140 of the New Castle Municipal Code is hereby repealed in its entirety.

D. Chapter 17.18 of the New Castle Municipal Code is hereby adopted in substantially the form attached hereto as Exhibit A

3. Effective Date. This Ordinance shall be effective fourteen days after final publication pursuant to section 4.3 of the Town Charter.

INTRODUCED on March 15, 2011, at which time copies were available to the Council and to those persons in attendance at the meeting, read by title, passed on first reading, and ordered published in full and posted in at least two public places within the Town as required by the Charter.

INTRODUCED a second time at a regular meeting of the Council of the Town of New Castle, Colorado on April 19, 2011, read by title and number, passed without amendment, approved, and ordered published as required by the Charter.

TOWN OF NEW CASTLE, COLORADO

By: Frank Breslin  
Frank Breslin, Mayor

ATTEST:

Melody Harrison  
Melody Harrison, Town Clerk  
642827-1



## Chapter 17.18

### SIGN CODE

#### 17.18.010. TITLE:

This chapter shall be known and cited as the New Castle Sign Code.

#### 17.18.020. PURPOSES:

- A. The regulations in this Chapter are intended to coordinate the use, placement, physical dimensions, and design of all signs within the Town of New Castle. The purposes for these regulations include:
1. To recognize that signs are a necessary means of visual communication for the convenience of the public and to provide flexibility within the sign review/approval process to allow for unique circumstances and creativity.
  2. To recognize and ensure the right of those concerned to identify businesses, services and other activities by the use of signs, and limit signs to those which are accessory and incidental to the use on the premises where such signs are located.
  3. To provide a reasonable balance between the right of an individual to identify his or her business and the right of the public to be protected against the visual discord resulting from the unrestricted proliferation of signs and similar devices.
  4. To protect the public from damage or injury caused by signs that are poorly designed or maintained and from distractions or hazards to pedestrians or motorists caused by the indiscriminate placement or use of signs.
  5. To conserve energy by supporting use of lighting elements that utilize light emitting diodes (LED), florescent bulbs and other low energy consuming lighting devices, thereby reducing energy demands.
  6. To promote conservation of energy by reducing or eliminating the over-lighting of signs and use of inefficient lighting systems.
  7. To support use of materials in structures that include recycled products and other materials that are designed for longevity and that minimize environmental impacts.
  8. To ensure signs are well designed and contribute in a positive way to the Town of New Castle's visual environment, express local character, and help develop a distinctive image for the Town of New Castle.
  9. To encourage signs which are responsive to the aesthetics and character of their particular location, adjacent buildings and uses, and the surrounding neighborhood.
  10. To ensure signs are compatible and integrated with a building's architectural design and with other signs on and near the property.
  11. To prevent unnecessary or excessive competition between signs in the town.
  12. To ensure signs are appropriate for where they are located.
  13. To provide mechanisms for bringing nonconforming signs into compliance with these regulations as a result of changing use, abandonment or other legal mechanisms.
  14. To establish sign districts that differentiate the types of signs allowed in specific areas based upon characteristics particular to that district.

### 17.18.030. DEFINITIONS:

As used in this chapter the following words have the following meanings:

**Above-roof sign** means a sign displayed above the peak or parapet of a building.

**Administrator or code administrator** means the town administrator or his or her designee.

**Animation or animated** (*See also changeable copy and ~~and~~ movement*) means the movement or the illusion of movement of any part of a sign's structure, design, or pictorial or text segment(s), including the movement of any illumination or the flashing or varying of light intensity; the automatic changing of all or any part of the facing of a sign.

**Architectural detail** (*See also sign area, wall and ~~and~~ roof sign*) means any projection, relief, cornice, column, change of building material, window, or door opening on any building.

**Architectural, historic, or scenic area** means an area that contains unique architectural, historic, or scenic characteristics that require additional regulations to ensure that signs enhance the visual character and are compatible with the area.

**Auxiliary sign** means a sign in addition to other signs associated with a business or use. The sign area of any auxiliary sign is calculated in the sum of total square footage for all signs. For example, an awning sign may be considered an auxiliary sign when used in conjunction with a wall sign for a business.

**Awning** means a cloth, plastic, or other nonstructural covering that either is not moveable and permanently attached to a building or can be raised or retracted to a position against the building when not in use.

**Banner** means a sign on a lightweight material that may be temporarily but not permanently affixed to a building or other structure and that may be affected by the movement of air.

**Bare-bulb illumination** means a light source that consists of light bulbs with a twenty (20)-watt maximum wattage for each bulb.

**Building** means a structure having a roof supported by columns or walls.

**Bulletin Board** means a type of changeable copy sign located on a premises used for temporary posting of bulletins, notices, events, meetings, but is not used to display commercial messages relating to products or services that are offered on the premises. Bulletin boards may be open or enclosed, and/or protected by glass, Plexiglas or a similar clear protective cover.

**Canopy** means a structure other than an awning which is made of cloth, wood, metal, or other material with frames affixed to a building and carried by a frame.

**Changeable copy** means copy that changes automatically at intervals of more than once every one hundred-eighty (180) seconds.

**Changeable copy - manual** means copy that is changed manually in the field.

**Clearance** means the smallest vertical distance between the grade of the adjacent street or street curb and the lowest point of any sign, including framework and embellishments, extending over that grade.

**Copy** means text, wording or numbers in either permanent or removable form.

**Directional sign** means a sign with a symbol indicating direction of travel and may be found, for example, at the exit or entrance of a premises that has two or more driveways or adjacent to a street off of the right-of-way when used for real estate purposes.

**Double-faced** means a sign with two faces.

**External illumination** means illumination of a sign that is affected by an artificial source of light not contained within the sign itself.

**Façade ~~or~~ facade** means the entire building front including the parapet and any other architectural details which faces and is parallel to or nearly parallel to a public or private street. There can be only one building façade for each street upon which a building faces.

**Face** means the area of a sign on which copy or graphics are placed.

**Flashing illumination** means illumination in which the artificial source of light is not maintained stationary or constant in intensity, color, or focus when a sign is illuminated.

**Frontage** means the length of the property line of any premises along a public right-of-way.

**Government sign** means any temporary or permanent sign erected and maintained by the Town, Garfield County, State of Colorado, federal government, or other duly organized and constituted governmental or quasi-governmental entity.

**Grand opening sign** means a sign or banner displayed on a premises indicating or conveying that a grand opening is in progress or pending.

**Graphics** means the presentation of information, logos, or symbols in the form of diagrams and illustrations instead of as words or numbers.

**Ground sign** means a sign supported by one or more uprights, posts, or bases placed upon or affixed in the ground and not attached to any part of a building. It includes a **pole sign** and a **monument sign**.

**Height** means the vertical distance measured from the highest point of the sign, excluding decorative embellishment, to the grade of the adjacent street or the surface grade beneath the sign, whichever is less.

**Identification sign** means a sign whose copy and graphics is limited to the name and address of a building, institution, or person and/or to the activity or occupation being identified.

**Illumination or illuminated** means a source of any artificial or reflected light, either directly from a source of light incorporated in, or indirectly from an artificial source, so shielded that no direct illumination is visible elsewhere than on and in the immediate vicinity of the sign.

**Incidental sign** means a small sign, emblem or decal informing the public of goods, facilities or services available on the premises, e.g., a credit card sign or a sign indicating open/closed and/or hours of business.

**Indirect illumination** means a source of external illumination, located away from the sign, that lights the sign, but which is itself not visible to persons viewing the sign from any street, sidewalk or adjacent property.

**Informational sign** means a sign that provides facts about business hours, open/closed, loading zones or a similar message without advertising a product, displaying a logo or otherwise conveying a commercial message.

**Internal illumination** means a light source that is concealed or contained within the sign and becomes visible through a translucent surface.

**Item of information** means a word, logo, abbreviation, symbol, or geometric shape.

**Legal nonconforming sign** means a sign that was lawfully constructed or installed prior to the adoption or amendment of this chapter and was in compliance with all of the provisions of the sign code then in effect, but which does not presently comply with this chapter. If a premises lawfully has more signs than this chapter would otherwise allow, any sign in excess of that number is nonconforming.

**Lot** means a parcel of land legally defined on a subdivision map recorded with the clerk and recorder or a parcel of land defined by a legal record or survey map.

**Marquee** means a permanent structure other than a roof, awning, or canopy which is attached to, supported by, and projecting from a building. Marquees are often, but not always, designed to accept the placement of changeable copy, typically for the purpose of announcing current or upcoming events at the premises.

**Monument sign** means a ground sign permanently affixed to the ground at its base, supported entirely by a base structure, and not mounted on a pole.

**Movement** (*See also animation*) means physical redirection or revolution up or down, around, or sideways that completes a cycle of change at set intervals.

**Multi-tenant building or multi-building complex** means a grouping of two or more business establishments that either share common parking on the lot where they are located, or that occupy a single structure or separate structures that are physically or functionally related or attached.

**Multi-use building** means a building consisting of more than one separate commercial use.

**Nameplate** means a non-electric on-premise identification sign giving only the name, address, and/or occupation of an occupant or group of occupants.

**Neon tube illumination** means a source of light for externally lit signs supplied by a tube filled with neon or other inert gas and which is bent to form letters, symbols, or other shapes.

**Occupancy** means the portion of a building or premises owned, leased, rented or otherwise occupied for a given use.

**Occupant** means a use or tenant located in a building and includes multi-use/multi-tenant buildings, or shopping centers.

**Off-premise sign** means a sign which is not related in manner to the property upon which it is located or which directs attention to a person, business, profession, or activity not conducted on the property in which it is located.

**Owner** means the person with legal title to all or a portion of a piece of property as evidenced by official records such as a deed or assessor's record. The owner of property on which a sign is located is presumed to be the owner of the sign unless facts to the contrary are officially recorded or otherwise brought to the attention of the administrator, e.g., a sign leased from a sign company.

**Painted wall sign** means any sign that is applied with paint or similar substance on the face of a wall.

**Parapet** means the extension of a false front or wall above a roofline.

**Pole cover** means the cover enclosing or decorating a pole or other structural support of a sign.

**Political Sign** means a sign used in connection with a local, state or national election or referendum or which advocates a political position.

**Peak** means the highest point on a roof or the highest point on another architectural element that blocks the rear view of a sign.

**Pole sign** means a freestanding sign that is permanently supported in a fixed location by a structure of poles, uprights, or braces from the ground and not supported by a building or a base structure.

**Portable sign** means a sign designed to be transported and not permanently attached to the ground or a building or designed to be permanently attached to the ground or a building including, but not limited to, menu and sandwich board signs.

**Premises** means the lot or lots, plots, portions, or parcels of land considered as a unit for a single use or development, whether owned or leased, and not located in a shopping center or multi-use building.

**Projecting sign** means a sign attached to and projecting from the wall of a building not in the same plane as the wall.

**Real estate sign** means a temporary sign advertising the real estate upon which the sign is located as being for rent, lease or sale.

**Roof sign** (*See also above-roof sign*) means a sign painted, erected, constructed, or maintained on the roof of a building; a sign that is displayed above the eaves and under the peak of a building.

**Shopping center** means a commercial development under unified control consisting of four (4) or more separate commercial establishments sharing a common building, or which are in separate buildings that share a common entranceway or parking area.

**Sign** means a lettered, numbered, symbolic, pictorial, or illuminated visual display of copy and/or graphics designed to identify, announce, direct, or inform and that is visible from a public right-of-way. The term "sign" includes banners, pennants, streamers, moving mechanisms, and lights, whether or not the device contains copy or graphics.

**Sign area** means the surface area that describes the largest square, rectangle, triangle, parallelogram, polygon or sphere as further defined under sign area calculations.

**Sign area calculations.**

**1. Awning, banner, bulletin board, canopy, changeable copy, creative, directional, identification, incidental, marquee, nameplate, off-premises, portable, real estate, suspended, or similar two-dimensional signs**

The area of the sign face within a continuous perimeter composed of a single rectangle, circle, triangle, or parallelogram enclosing the extreme limits of characters, lettering, illustrations, ornamentations, or other figures shall be counted in calculating sign area.

**2. Pole and monument signs:**

a. **Signs composed of one or two individual sign faces:** The area of the single largest sign face (if the sign faces are different sizes) shall be counted in calculating sign area by using the following formula. The area enclosing the perimeter shall be summed to determine total sign area. The perimeter of measurable area shall not include embellishments such as pole covers, framing, decorative roofing, etc., provided that there is not written advertising copy on such embellishments.

b. **Signs composed of more than two sign faces:** The area enclosing the entire perimeter of each sign face shall be calculated and shall be summed with all other sign faces and divided by one half to determine total sign area. The perimeter of measurable area shall not include embellishments such as pole covers, framing, decorative roofing, etc., provided that there is not written advertising copy on such embellishments.

**3. Projecting signs**

The area of the single largest sign face (if the sign faces are different sizes) within a continuous perimeter composed of a single rectangle, circle, triangle, or parallelogram enclosing the extreme limits of characters, lettering, illustrations, ornamentations, or other figures shall be counted in calculating sign area.

**4. Wall signs**

The area of the sign face free of architectural details on the facade of a building or part of a building within a continuous perimeter composed of a single rectangle, circle, triangle, or parallelogram enclosing the extreme limits of characters, lettering, illustrations, ornamentations, or other figures shall be counted in calculating sign area.

**5. Other signs**

Other signs that do not fall into any single sign area calculation category due to geometry, design or other characteristics shall be calculated using one or more of the most applicable aforementioned methodologies and based upon the more restrictive area calculation method as determined by town staff.

**Sign District Map** means the map accompanying and to be used with these regulations that identifies the boundaries of each sign district enumerated in these regulations.

**Size** means the total area of the face used to display a sign, not including its supporting poles or structures. If a sign has two faces that are parallel, not more than two (2) feet apart and supported by the same poles or structures, the size of the sign is one-half the area of the two faces. Spherical sign area shall be the entire surface of the sphere. The total area of multi-faced signs (more than two faces) shall be one-half the area of the two smallest faces plus the total area of all faces greater than the two smallest.

**Structure** means anything which is built or constructed, an edifice or building of any kind or any piece of work artificially built or composed of parts joined together in some definite manner. This term includes a building.

**Subdivision identification sign** means a freestanding or wall sign identifying a recognized subdivision, condominium complex, or residential development.

**Suspended sign** means a sign that is suspended from the underside of a horizontal plane surface of a building or structure such as a canopy, porch ceiling or portico and is typically used as a pedestrian scale sign.

**Temporary sign** means a non-permanent sign to be displayed for an individual time period of thirty (30) days or less, as provided in this Chapter.

**Temporary window sign** means a window sign displayed for a limited period of time.

**Town** means the town of New Castle, Colorado.

**Unified Sign Band** means a coordinated arrangement of signs on a structure with the same design style, font type, sign face, height and similar characteristics that create a unified appearance.

**Use** means the purpose for which a building, lot, sign or structure is intended, designed, occupied or maintained.

**Wall sign** means a sign painted on or attached directly to an exterior wall of a building or that which is dependent upon a building for support, with the exposed face of the sign located in a place substantially parallel to the exterior building wall to which the sign is attached or which supports the sign.

**Window sign** means a sign applied, painted or affixed to or in the window of a building. A window sign may be temporary or permanent.

#### **17.18.040. SIGN PERMITS AND ADMINISTRATION**

A. **Sign Permit Required.** To ensure compliance with the regulations of this Chapter, a sign permit shall be required in order to erect, move, alter, reconstruct or repair any permanent or temporary sign, except signs that are exempt as set forth in Section 17.18.050 (Exempt Signs). In multi-tenant buildings, a separate permit shall be required for each business entity's sign(s). Separate building and electrical permits may be required for signs and will be determined on a case-by-case basis. Changing or replacing the copy or graphics on an existing lawful sign shall not require a permit, provided the change does not result in a violation of this Chapter.

B. **Temporary Signs and Banners.** The Town may approve temporary sign permits subject to the following:

- a. Grand opening signs may only be displayed for a period not to exceed thirty (30) consecutive days;
- b. Signs displayed in conjunction with a special sale or other event such as hunting season may only be displayed for a period not to exceed four (4) thirty (30) day periods within any 365 day time period. The 30-day time periods may not be further subdivided or prorated throughout the year for purposes of extending the display timeframe;
- c. The banner or temporary sign shall be securely attached to the wall of the establishment, freestanding signs or properly designed and structurally sound poles or posts on private property;
- d. One (1) banner or temporary sign per street frontage per establishment shall be permitted unless more than one business occupies the same building. In that case, each business may be allowed to display a banner or temporary sign. However, the other limitations of this section shall not be increased by the number of businesses at a location.
- e. Prior to display the Staff must affix a weatherproof semi-permanent temporary sign permit approval sticker to each banner or temporary sign to document approval and timeframe for display.

C. **Application for a Sign Permit.**

1. Sign Permit Application Requirements. Applications for sign permits shall be made in writing on forms furnished by Staff. The application shall contain:
  - a. The location by street number and the legal description of the property upon which the proposed sign structure is to be located;



- b. Names and addresses of the property owner, applicant (if different from the property owner), sign contractor and erectors;
  - c. Evidence of a current New Castle contractor's license may be required at the sole discretion of the town administrator depending on the nature of the sign;
  - d. Legible accurately scaled plan which includes the specific location of the sign and setbacks to adjacent property lines and buildings;
  - e. A detailed accurately scaled drawing indicating the dimensions, materials, and colors of the proposed sign structure. A certification by a structural engineer may be required by Staff for a freestanding or projecting sign;
  - f. A graphic drawing or photograph of the sign;
  - g. A description of the lighting to be used including a listing of the energy conservation measures incorporated in sign (light fixture type(s), materials used etc.), fixture specifications, bulb type, wattage and placement, and an estimate of energy consumption by the sign;
  - h. Proof of premises liability insurance covering freestanding, projecting and wall signs;
  - i. If the sign is to be located off the premises listed in the application, a written lease or permission from the property owner of the site on which the sign will be located; and
  - j. Payment of a nonrefundable sign permit fee as established by the current fee schedule. The applicant shall pay all costs billed by the Town of New Castle relative to the review of the application including review fees by outside consultants. Approved sign permit applications shall expire 6 months from the date of issuance if installation of the sign has not been completed. A single six (6) month extension may be granted administratively upon completion of an extension application including a written narrative by the applicant explaining the basis for the extension request and payment of an extension application fee.
2. Sign Permit Application Review of Completion. Within fifteen (15) business days of the date of submission of an application, the administrator or his/her designee shall determine whether the application is complete. If the application is deemed incomplete the administrator shall give written notice of the deficiency to the applicant. The applicant shall have fifteen (15) business days (or such other additional time as administrator may grant in his or her sole discretion) to correct the deficiency or the administrator may deny the application for failure to achieve completeness.
3. Review and Approval. When the application has been determined to be complete, the administrator or his or her designee shall review the sign permit in accordance with the established review criteria. Within fifteen (15) business days of the determination of completeness the administrator must issue a written decision on the application. The administrator may approve, approve with conditions or deny the sign permit. Upon approval of the sign permit, the sign permit and any building permits required for the sign must be obtained by the applicant prior to construction. Electrical permits, if required, shall be obtained from the state electrical inspector and evidence of an approved permit shall be provided to the Town prior to construction.
- D. **Sign Permit Review Criteria.** The following review criteria will be used by the Town of New Castle Staff to evaluate all sign permit applications:
- 1. Sign meets the requirements of this Chapter;
  - 2. Sign conforms to the requirements of all applicable codes including, but not limited to,

- building and electrical codes;
3. Sign conforms to the applicable zoning requirements, including but not limited to, size, height, material and location for the zoning and sign district in which it is located;
  4. Sign would not create visual obstructions which adversely impact public safety and/or that otherwise interfere with pedestrian or vehicular safety;
  5. Sign would not detract from the character of an architectural, historic, or scenic area;
  6. Sign would not be located so as to have a negative impact on adjacent residential property including, but not limited to, impacts from excessive lighting, shading of or impairment of solar access, visibility of or from public rights-of-way and similar adverse impacts;
  7. Sign would not impair pedestrian access of a street or area; and
  8. Sign would not add to an over-proliferation of signs on a particular property or area.

**E. Appeals.**

1. An applicant may file an appeal of the administrator's decision on a sign permit application to the Town Council for any of the reasons set forth below. Sign application appeals to the Town Council shall be filed with the town clerk no later than ten (10) calendar days after the date of action by the administrator. The following items constitute a basis upon which an applicant may file an appeal. Notice of appeal shall be in writing and shall state specifically any action appealed from and the grounds for such appeal.
  - a. Failure of the administrator to provide a written response concerning completion of an application within fifteen (15) calendar days of the town's receipt of the sign permit application.
  - b. Any written decision rendered by the administrator concerning a permit or an interpretation of this Chapter.
2. The action being appealed shall be held in abeyance pending the decision of the Town Council. The appeal shall be heard by the Town Council at the next available town council meeting, as determined by the Town Clerk. The Town Council shall review the decision of the administrator under the same criteria applied by the administrator. The Town Council is not bound by the findings and determinations of the administrator, but may give such findings deference as determined by Town Council.

**F. Variances.** Any variance requested in association with a sign shall be processed pursuant to the provisions of Chapter 17.12 of the New Castle Municipal Code.

**17.18.050. EXEMPT SIGNS**

- B. Exempt Signs.** The following types of signs are exempt from permit requirements of this Chapter and may be placed in any zoning/sign district subject to the provisions of this Chapter. Such signs shall otherwise be in conformance with all applicable requirements contained in this Chapter. All such signs (except government signs) shall be located outside of public street right-of-way. Signs shall not interfere with traffic signs or the sight distance triangle at intersections. Evidence of owner's permission to install sign may be required. All other signs shall be allowed only with permit and upon proof of compliance with this Chapter.
1. Address. Non-illuminated signs not to exceed two (2) square feet in area which identify the address and/or occupants of a building.
  2. Building Identification, Historical Markers. Non-illuminated signs not exceeding four (4) square feet, constructed of metal, wood or masonry which are permanently affixed to buildings or structures for the purpose of identifying the name of a building, date of erection or other historical information as approved by Staff.

3. Bulletin Board. Bulletin board signs not exceeding fifteen (15) square feet in gross surface area accessory to a church, school, or public or nonprofit institution.
4. Construction. Temporary construction signs provided that:
  - a. Such signs are installed in association with an active building permit and are removed upon issuance of a certificate of occupancy or expiration of the building permit.
  - b. Signs in conjunction with any residential use shall not exceed eight (8) square feet each.
  - c. All temporary construction signs at a single construction site shall have a maximum sign area of thirty-two (32) square feet.
  - d. Temporary construction signs shall be oriented to public or private streets.
  - e. Such signs shall not be illuminated.
  - f. Such signs shall only be installed on the private property on which the construction activity is located.
  - g. Such signs shall be removed within seven (7) days after issuance of a certificate of occupancy.
5. Incidental Sign. Non-illuminated or indirectly illuminated signs which identify, as a courtesy to customers, items such as credit cards accepted, redemption stamps offered, menus or prices; limited to one (1) such sign for each use, not to exceed four (4) square feet or eight (8) square feet in total area. Such signs may be attached to the building, as projecting or wall signs, suspended from a canopy or included as an integral part of a freestanding sign or placed in window.
6. Decorations (Holiday). Temporary decorations or displays, when such are clearly incidental to and are customarily and commonly associated with any national, state, local or religious holiday or celebration; provided that such signs shall be displayed for not more than sixty (60) days in any one (1) year; and may be of any type, number, area, height, location, illumination or animation.
7. Directional. On-premise directional and instructional signs not exceeding four (4) square feet in area apiece.
8. Business Identification Window Sign. Signs affixed, painted on or otherwise attached to door glass which identifies the name and/or address of an establishment.
9. Farm Products. Temporary farm product signs, including farmers markets, provided that:
  - a. One on-premises sign may be used. Said sign shall be located off the street right-of-way. Such sign shall have a maximum sign area of nine (9) square feet and may not be illuminated.
  - b. A maximum of two (2) off-premise signs shall be permitted. Said off-premise signs may be no greater than four (4) square feet apiece and shall not be illuminated. No such sign shall be allowed in the street right-of-way nor within ten (10) feet of a side lot line. No off-premises sign shall be located on property without the expressed written consent of the property owner.
10. Flags. Flags, crests or banners of nations, or organizations of nations, or states and cities, or professional fraternal, religious, or civic organizations, except when displayed in connection with commercial promotion and do not exceed thirty (30) square feet.
11. Garage, Estate, Yard Sale or Farm Auction. Signs which advertise a private garage or yard sale on the lot on which the sign is located; provided such signs are displayed no

more than two (2) times per year per dwelling unit for a period not to exceed three (3) days.

12. Hazards. Temporary or permanent signs erected by the Town of New Castle, public utility companies, oil and gas companies, or construction companies to warn of danger or hazardous conditions, including signs indicating the presence of underground cables, gas lines and similar devices.
13. Memorial. Memorial signs, plaques or grave markers which are noncommercial in nature.
14. Merchandise. Merchandise, pictures or models of products or services which are incorporated as an integral part of a window display.
15. Political. Political signs displayed on private property.
16. Public Information. Signs which identify restrooms, public telephones or provide instructions as required by law or necessity, provided the sign does not exceed two (2) square feet in area or as approved by Staff and is non-illuminated, internally illuminated or indirectly illuminated. (This category shall be interpreted to include such signs as “no smoking,” “restrooms,” “no solicitors,” “self-service” and similar informational signs.)
17. Religious Symbols. Religious symbols located on a building or lot used for organized religious services.
18. Regulatory Signs. Regulatory signs erected on private property, such as “no trespassing” signs, which do not exceed two (2) square feet per face or four (4) square feet in total surface area, limited to four (4) such signs per use or per building, whichever is the greater number.
19. Sandwich Board Signs. A single temporary portable sign not exceeding four (4) square feet and no more than eighteen (18) inches wide placed in front of the business and only during business hours on sidewalk in a manner that does not present a risk to public safety, accessibility (including handicap) or visibility.
20. Sale, Lease, Rent. Temporary signs used to offer for sale, lease or rent the land, business or buildings upon which the sign is located provided:
  - a. One (1) sign per street frontage advertising real estate ("For Sale", "For Rent", "For Lease" or "For Development") not greater than eight (8) square feet in area in a residential district and thirty-two (32) square feet in area in nonresidential districts may be located on the property being advertised so long as said sign is located behind the street right-of-way line. If the property so advertised lies on a corner lot or double frontage lot, then a second sign may be oriented along the second street so long as the two signs are at least one hundred (100) feet apart as measured by the shortest straight line.
  - b. In addition to the on-site real estate sign(s), a maximum of three (3) directional signs, each not exceeding four (4) square feet in area, shall be permitted off the subject premises. Such signs must be placed outside all existing right-of-ways. The message of said signs shall be limited to the name of the real estate company property, development being advertised, an address, a telephone number, a directional arrow, mileage to the subject property, and the terms "Lot/Business/Home/ For Sale," "For Rent," "For Lease," "For Development," "Open House," etc.
  - c. No more than three (3) temporary directional signs advertising a specific planned commercial or mixed use development, subdivision, multi-family development, etc. may also be permitted offsite. Each such sign may have a maximum sign

- area of four (4) square feet and shall be placed outside all existing right-of-ways.
- d. All off premises real estate signs or directional signs shall require expressed written approval from the landowner on which the sign or signs are to be located.
  - e. All such temporary signs shall be removed within seven (7) days after the real estate closing or lease transaction.
  - f. No sign allowed under this subsection shall be lighted.
21. Scoreboards. Scoreboards for athletic fields.
  22. Special Events. Temporary special event signs and banners for religious, charitable, civic, fraternal or similar not-for-profit organizations provided that:
    - a. Signs shall be erected no sooner than fifteen (15) days prior and removed no later than seven (7) days after the event.
    - b. No such sign shall exceed thirty-two (32) square feet.
    - c. No such sign shall be illuminated.
    - d. All such signs shall be located off the street right-of-way, unless otherwise granted permission for such location by the Town of New Castle or the Colorado Department of Transportation (CDOT). In no case may any such sign impede the view or travel of any motorists or pedestrians or be attached to any structure within the right-of-way (government signs, telephone poles, etc.)
  23. Strings of Light Bulbs. Displays of string lights, provided:
    - a. They are steady burning, clear, non-colored bulb lights. No blinking, flashing, intermittent changes in intensity or rotating shall be permitted.
    - b. They are no greater in intensity than five (5) watts.
    - c. They shall not be placed on or used to outline signs, sign supports, awnings and/or canopies.
    - d. They shall not be assembled or arranged to convey messages, words, commercial advertisements, slogans and/or logos.
    - e. They shall not create a safety hazard with respect to placement, location of electrical cords or connection to power supply.
    - f. They shall be placed only on private property.
    - g. They shall be maintained and repaired so that no individual light bulb is inoperative. In the event the bulbs are not maintained or repaired, the string lights may be removed at the expense of the owner after giving notice to the owner pursuant to this Chapter.
  24. Text. No permit shall be required for text or copy changes on conforming or legal nonconforming signs specifically designed to permit changes of the text or copy; provided that there are no structural changes, changes to sign area, change in illumination or other modifications.
  25. Time and Temperature. Signs displaying time and temperature devices provided they are not related to a product.
  26. Traffic Control. Signs for the control of traffic or other regulatory purposes including signs for the control of parking on private property, and official messages erected by, or on the authority of, a public officer in the performance of his/her duty.
  27. Vacancy and No Vacancy. All “vacancy” and “no vacancy” signs, where they are non-illuminated, internally illuminated, indirectly illuminated or directly illuminated signs;

provided that the area of the sign does not exceed two and one-half (2½) square feet per face. Also, signs designed to indicate vacancy such as “yes,” “no” or “sorry” shall also be exempt under the provisions of this paragraph if they meet the area requirement.

28. Vehicular For Sale Signs. Motor vehicle for sale signs provided there is only one (1) sign per vehicle, the sign does not exceed two (2) square feet, and the vehicles are located on private property.
29. Vehicular Signs. Signs displayed on trucks, buses, trailers or other vehicles which are regularly being operated or stored in the normal course of a business, such as signs indicating the name of the owner or business which are located on moving vans, delivery trucks, rental trucks and trailers and the like, shall be exempt from the provisions of this Chapter, provided that the primary purpose of such vehicles is not for the display of signs, and provided that they are parked or stored in areas appropriate to their use as vehicles for periods that do not exceed thirty (30) days.
30. Vending Machine Signs. A sign permit shall not be required for vending machine signs provided that the advertisement upon the vending machine sign is limited to the product vended.

#### **17.18.060 PROHIBITED SIGNS**

A. **Prohibited Signs.** The following signs are inconsistent with the purposes and standards in this Chapter and are prohibited in all zoning districts.

1. Animated signs or signs that flash, rotate, blink or moving signs, signs with moving, rotating or flashing lights or signs that create the illusion of movement, except for time and temperature devices.
2. Any sign that is erected in such a location as to cause visual obstruction or interference with motor vehicle traffic, or traffic-control devices including any sign that obstructs clear vision in any direction from any street intersection or driveway.
3. Mechanical or electrical appurtenances, such as “revolving beacons,” that are designed to attract attention.
4. Off-premises signs (except as otherwise noted herein).
5. Any sign which interferes with free passage from or obstructs any fire escape, downspout, window, door, stairway, ladder or opening intended as a means of ingress or egress or providing light or air.
6. Any sign located in such a way as to intentionally deny an adjoining property owner visual access to an existing sign.
7. Vehicle-mounted signs, including but not limited to, signs painted on or attached to semi-trailers or cargo containers when exhibited on private property adjacent to public right-of-way for the purpose of advertising the business or services offered on the property. Vehicle-mounted signs used in connection with a special event are exempted from the requirements of this section during the duration of the special event only and not exceeding seventy-two (72) hours. Upon the conclusion of the special event, such signs must be dismantled. For the purposes of this subsection, the term special event shall mean a parade, circus, fair, carnival, festival, farmers’ market or other similar event that is different in character from the customary or usual activities generally associated with the property upon which the special event is to occur.
8. Portable signs or signs not permanently affixed or attached to the ground or to any structure, except as permitted by this Chapter.
9. Searchlights.

10. Signs with optical illusion of movement by means of a design which presents a pattern capable of reversible perspective, giving the illusion of motion or changing of copy.
11. Inflatable freestanding signs or tethered balloons or other inflatable figures or devices installed with the primary purpose of attracting attention.
12. Stationery or portable electronic message boards except governmental signs.
13. Wind signs designed or installed to be activated by movement of the atmosphere.
14. Any sign (together with its supporting structure) now or hereafter existing which, ninety (90) days or more after the premises have been vacated, advertises an activity, business, product or service no longer produced or conducted upon the premises upon which such sign is located. If the sign or sign structure is covered or the identifying symbols or letters removed, an extension of time may be granted by the Building Official upon good cause for such extension being shown. (This provision shall not apply to permanent signs accessory to businesses which are open only on a seasonal basis, provided that there is clear intent to continue operation of the business).
15. Any sign or sign structure which:
  - a. Is structurally unsafe;
  - b. Constitutes a hazard to safety or health by reason of inadequate maintenance or dilapidation;
  - c. Is not kept in good repair; or
  - d. Is capable of causing electrical shocks.
16. Any sign or sign structure which:
  - a. In any other way obstructs the view of, may be confused with or purports to be an official traffic sign, signal or device or any other official sign;
  - b. Uses any words, phrases, symbols or characters implying the existence of danger or the need for stopping or maneuvering a motor vehicle;
  - c. Creates in any other way an unsafe distraction for motor vehicle operators or obstructs the view of motor vehicle operators entering a public roadway from any parking area, service drive, private driveway, alley or other thoroughfare.

**17.18.070 REMOVAL, ENFORCEMENT, AND PENALTIES**

**A. Removal of Signs.**

1. Discontinued Establishments Whenever a business, industry, service or other use is discontinued, the sign(s) pertaining to the use shall be removed by the person or entity owning or having possession over the property within ninety (90) days after the discontinuance of such use.
2. Removal of illegal signs in the public right-of-way. The Town of New Castle may cause the removal of any sign within the public right-of-way or on property that is otherwise abandoned that has been placed there without first complying with the requirements of this Chapter.
3. Storage of removed signs. Signs removed by the Town or its designee in compliance with this Chapter shall be stored by the Town of New Castle for thirty (30) days, during which they may be recovered by the owner only upon payment to the Town of New Castle for costs of removal and storage. If not recovered within the thirty (30)-day period, the sign and supporting structure shall be declared abandoned and title shall vest with the Town of New Castle. The costs of removal and storage, up to thirty (30) days, may be billed to the owner. If not paid, the applicable costs may be imposed as a tax lien

against the property.

- B. **Enforcement.** The provisions of this Chapter shall be enforced by the administrator.
- C. **Penalties.** Violations of this Chapter shall be subject to the penalties of the Town of New Castle Municipal Code Section 17.96.

**17.18.080 MEASUREMENT OF SIGN AREA AND HEIGHT**

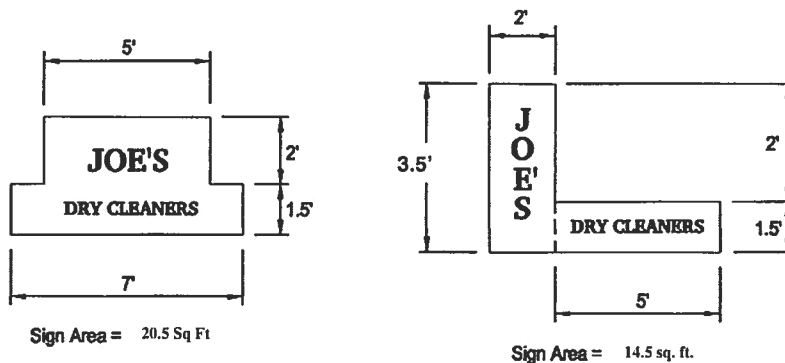

**SIGN AREA MEASUREMENT**

**Figure 7-1**

- A. **Sign Surface Area.** The area of a geometric shape enclosing any message, logo, symbol, name, photograph or display face shall be measured using standard mathematical formulas. Time and temperature devices shall not be included within the measurement of maximum sign area.
- B. **Sign Support.** Supporting framework or bracing that is clearly incidental to the display itself and does not include logos, advertising text or similar commercial messages shall not be computed as sign area.
- C. **Back-to-Back (Double-Faced) Signs.** Back-to-back signs shall be regarded as a single sign only if mounted on a single structure, and the distance between each sign face does not exceed two (2) feet at any point.
- D. **Three-Dimensional Signs.** Where a sign consists of one or more three-dimensional objects (i.e. balls, cubes, clusters of objects, sculpture), the sign area shall be measured as their maximum projection upon a vertical plane. Signs with three-dimensional objects that exceed a projection of six (6) inches from the sign face may be approved in compliance with **Section 7.18.120** (Creative Signs).
- E. **Wall Signs.** The area of a rectangle or geometric shape that most closely outlines the sign face or letters of the sign shall be the calculated sign area.
- F. **Sign Height.** The height of a sign shall be measured from the highest point of a sign, excluding decorative embellishment, to the grade of the adjacent street or the surface grade beneath the sign, whichever is less. When berms are used in conjunction with signage, the height of the sign shall be measured from the mean elevation of the fronting street.



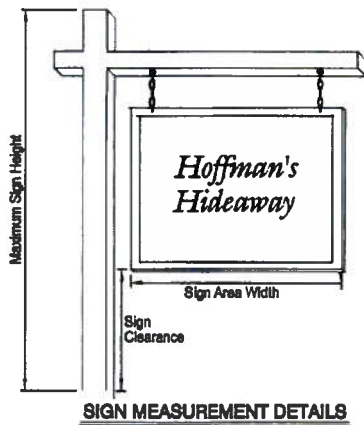

**SIGN MEASUREMENT DETAILS**

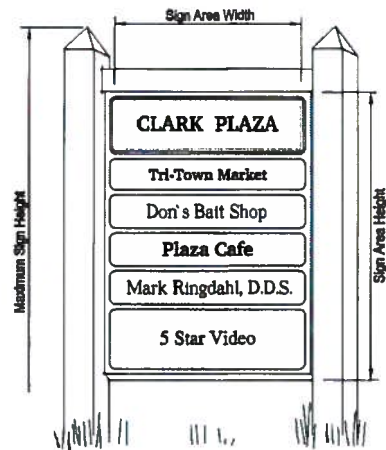

**Figure 7-2**

**17.18.090 SIGN DESIGN**

**A. Design compatibility.**

1. Creative design encouraged. Signs shall make a positive contribution to the general appearance of the street and commercial area in which they are located. A well-designed sign can be a major asset to a building. The Town of New Castle encourages imaginative and innovative sign design. The creative sign application procedure (**Section 7.18.120**) is specifically designed for artistic and unusual signs that might not fit the standard sign regulations and categories.
2. Proportionate size and scale. The scale of signs shall be appropriate for the building on which they are placed and the area in which they are located. Building signs shall be compatible in scale and proportion to the building facade upon which they are mounted.
3. Sign location and placement.
  - a. *Visibility* – Signs shall not visually overpower nor obscure architectural features.
  - b. *Integration with the building and landscaping* – **Carefully coordinate the sign** Signs shall be carefully coordinated with the architectural design, overall color scheme and landscaping. Signs shall be designed to complement or enhance the other signs for a building.
  - c. *Unified sign band* – Whenever possible, signs located on buildings with the same block-face shall be placed at the same height, in order to create a unified sign band. **Locate W** wall signs may be located at the first floor level only for retail uses.
  - d. *Monument signs* – Monument signs should be located in a planter setting within a landscaped area at the primary entries to residential, commercial and industrial subdivisions to provide an overall project identity.
  - e. *Pedestrian-oriented signs* – Pedestrian-oriented signs are encouraged. It is desirable to include a pedestrian-oriented sign as one of the permitted signs for a business. These signs are designed for and directed toward pedestrians so they can easily and comfortably read the sign as they stand on a sidewalk or location adjacent to the business.
  - f. *Road right-of-way* – No sign shall be erected within the road right-of-way or near the intersection of any road(s) or driveways in such a manner as to obstruct free and clear vision of motorists or pedestrians or at any location where, by reason of the position, shape or color, it may interfere with, obstruct the view of, or be

confused with any authorized traffic sign, signal or device. Signs located at an intersection must be outside of the sight distance triangle.



**THIS**

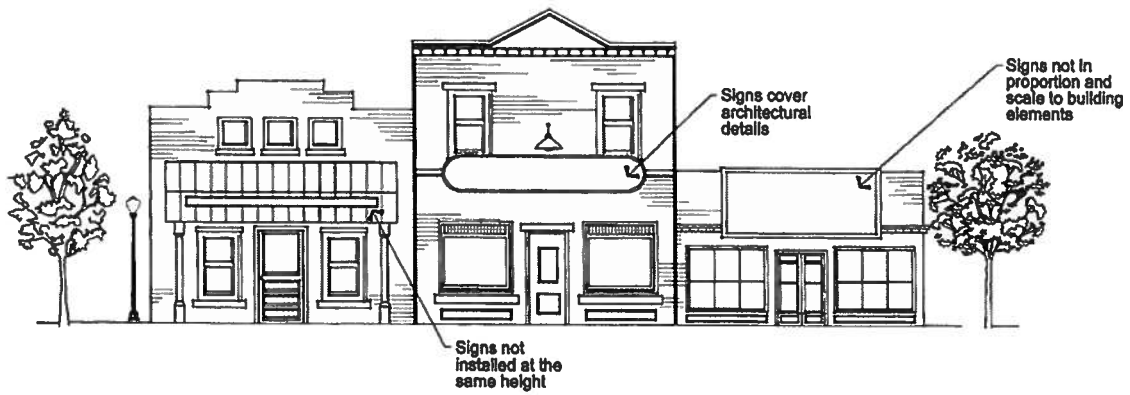

**NOT THIS**

**Figure 7-3**

4. Landscaping. Freestanding signs shall be landscaped at their base in a way harmonious with the landscape concept for the whole site. Landscaping shall form an attractive, dense cluster at the base of the sign that is equally attractive in winter and summer.

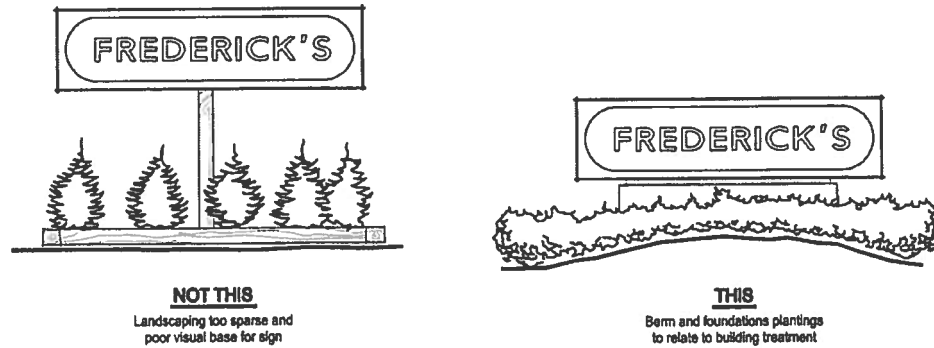
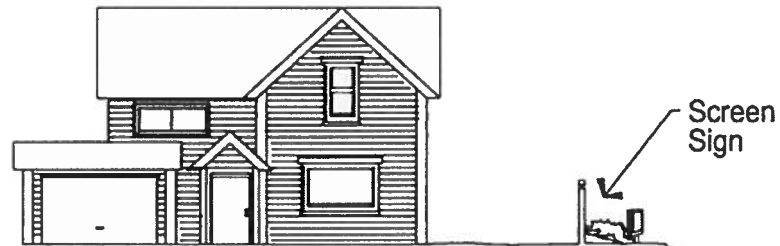

Figure 7-4

5. Low impact signs. Signs adjacent residential neighborhoods shall be designed and located so that they have little or no impact on residential areas,. Small-scale signs are encouraged.



**REDUCE SIGN IMPACT**

Figure 7-5

**B. Color.**

1. Color selection. Colors shall be selected to contribute to legibility and design integrity. Sign colors shall complement the colors used on the structures and the project as a whole. Colors or combinations of colors that are harsh and disrupt the visual harmony and order of the street are unacceptable.
2. Contrasting colors. Substantial contrast between the color and the material of the background and the letters or symbols will make the sign easier to read during both the day and night. Light letters on a dark background or dark letters on a light background are most legible.
3. Excessive colors. Colors or color combinations that interfere with legibility of the sign copy or that interfere with viewer identification of other signs shall be avoided.

**C. Materials.**

1. Signs shall be constructed of durable, high quality architectural materials. The sign package must use materials, colors and designs that are compatible with the building facade. Sign materials must be of proven durability. Treated wood, manufactured composite products with ingredients that use recycled materials, painted/treated/patina metal, stone, brick and stucco are the preferred materials for signs.

**D. Legibility.**

1. Signs shall be adequately legible under the circumstances in which they are primarily seen. The legibility of signs is related to:
  - a. The speed at which they are viewed;
  - b. Distance from the edge of the right-of-way
  - c. The context and surroundings in which they are seen; and
  - d. The design, colors and contrast of the sign copy and sign face.
  - e. The design of the sign including copy, lettering size and style, and colors shall logically relate to the average speed of the traffic which will see it. Signs shall legibly convey their messages without being distracting or unsafe to motorists reading them. Symbols and logos can be used in place of words whenever appropriate.

**E. Sign Illumination.**

1. Unnecessary lighting is to be avoided.

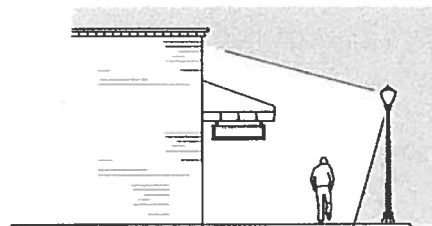

**USE OF EXISTING ILLUMINATION**

**Figure 7-6**

2. Sign illumination shall complement, not overpower, the overall composition of the site.
3. All lighted signs incorporating a direct light source shall be designed to direct lighting to

illuminate only the face of the sign. External light sources aimed at a sign shall be concealed from pedestrians' and motorists' lines of sight.

4. Signs must be illuminated in a way that does not cause lighting trespass, illumination of adjacent properties, over-lighting or glare onto the street and adjacent properties. Signs shall be lighted only to the minimum level for nighttime readability.

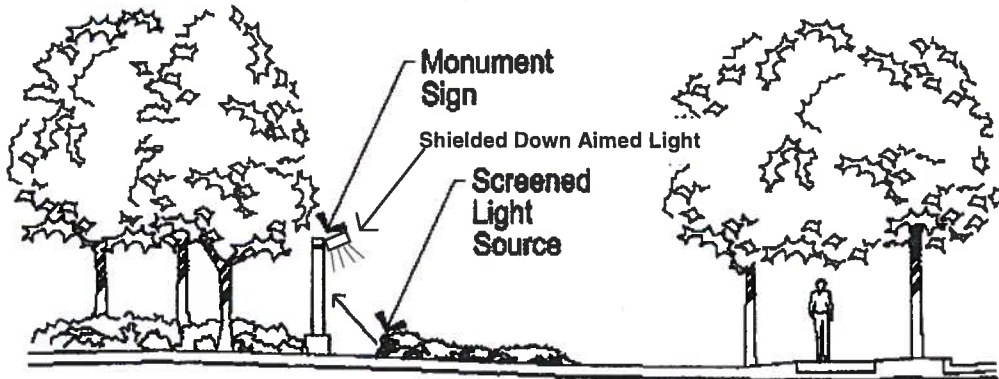

External light sources directed at signs should be concealed from pedestrians' and motorists' "lines of sight"

Figure 7-7

5. All lighted signs shall meet all applicable electrical codes and the electrical components used shall bear the label of an approval agency. Additionally, electrical permits shall be obtained for electric signs.
6. Flashing, moving, blinking, chasing or other animation effects shall be prohibited on all signs except time and temperature signs.
7. Neon tubing is an acceptable method of sign illumination for window signs in commercial districts.
8. The use of individually cut, back-lit letter signs is encouraged.
9. The use of solar electric lighting devices to illuminate signs is encouraged

#### 17.18.100 SIGN INSTALLATION AND MAINTENANCE

1. Projecting signs shall be mounted so they generally align with others in the block.
2. Owners of signs extending over public right-of-way shall be required to maintain public liability insurance in an amount to be determined appropriate by the Town of New Castle, in which the Town of New Castle is named as an "other or named insured."
3. All signs and all components thereof, including sign structures and sign faces, shall be kept neatly painted, in a good state of repair and in compliance with all building and electrical codes so ~~it does~~ they do not constitute a hazard to safety, health or public welfare by reason of inadequate maintenance, dilapidation or obsolescence.
4. The owner of a sign and the owner of the premises on which such sign is located shall be jointly and severally liable to maintain such sign, including any illumination sources in neat and orderly condition, and in a good working order at all times, and to prevent the development of any rust, corrosion, rotting or other deterioration in the physical appearance or safety of such sign. The sign must also be in compliance with all building and electrical codes.
5. The owner of any sign regulated by this Chapter shall be required to keep signs and

supporting hardware, including temporary signs and time/temperature signs structurally safe, clean, free of visible defects and functioning properly at all times. Repairs to signs shall be equal to or better in quality of materials and design than the original sign.

6. The Town of New Castle may inspect any sign governed by this Chapter and shall have the authority to order the painting, repair, alteration or removal of a sign which constitutes a hazard to safety, health or public welfare by reason of inadequate maintenance, dilapidation or obsolescence.

#### 17.18.110 STANDARDS FOR SPECIFIC TYPES OF SIGNS

- A. **Awning Signs.** An awning sign is a wall sign which is painted, stitched, sewn or stained onto the exterior of an awning. An awning is a movable shelter supported entirely from the exterior wall of a building and composed of non-rigid materials except for the supporting framework.

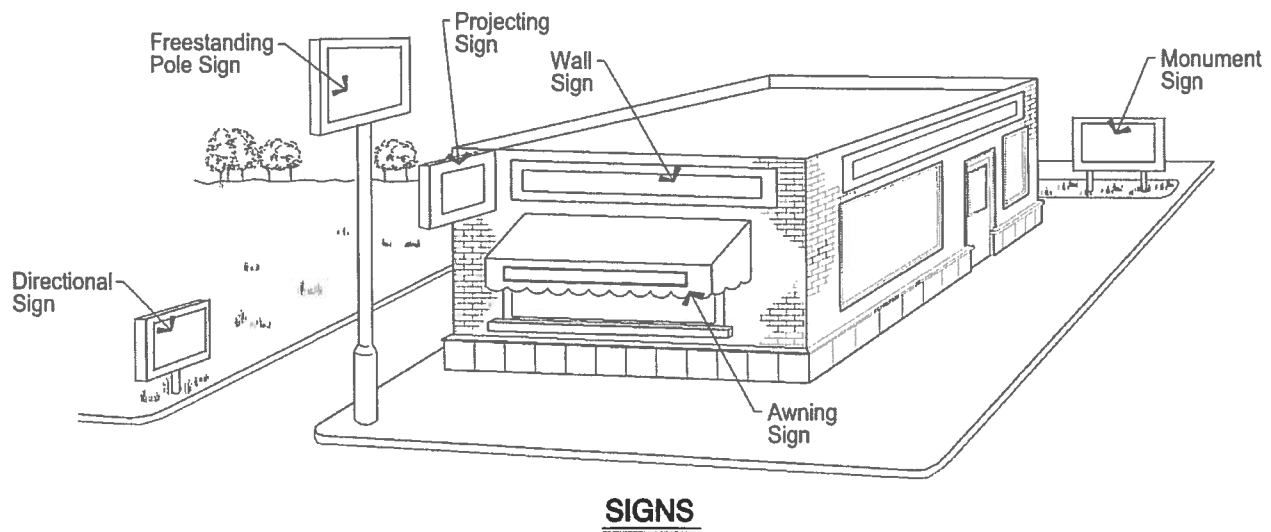
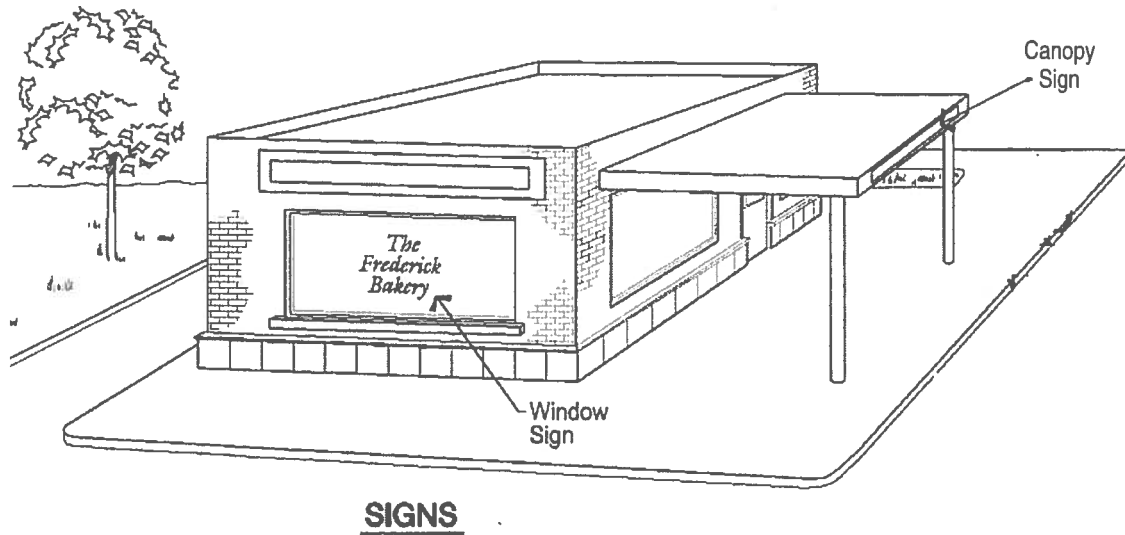

Figure 7-8

1. **Location.** Signs may be placed only on awnings that are located on first- and second-story building frontages, including those fronting a parking lot or pedestrian way. No awning sign shall project beyond, above or below the face of an awning.
2. **Maximum area and height.** Sign area shall comply with the requirements established by 17.18.130 Sign Matrices. No structural element of an awning shall be located less than eight (8) feet above finished grade. Awnings on which awning signs are mounted may extend over a public right-of-way no more than seven (7) feet from the face of a supporting building but in no case shall extend over a roadway or parking area. No awning, with or without signage, shall extend above the roof line of any building.
3. **Lighting.** Awnings shall not be internally illuminated except as part of a creative sign. Lighting directed downwards that does not illuminate the awning is allowed.
4. **Required maintenance.** Awnings shall be regularly cleaned and kept free of dust and

visible defects.

- B. **Canopy Signs.** A canopy sign is a wall sign that is permanently affixed to a roofed shelter attached to and supported by a building, by columns extending from the ground or by a combination of a building and columns.



**Figure 7-9**

1. **Maximum area and height.** Sign area shall comply with the requirements established by 17.18.130 Sign Matrices. No canopy, with or without signage, shall extend above the roof line of any building. No canopy sign shall project above the top of the canopy upon which it is mounted. However, such signs may project horizontally from the face of a canopy the distance necessary to accommodate the letter thickness and required electrical equipment, but not more than twelve (12) inches (measured from the bottom of the sign). Under-canopy signs which are perpendicular to the face of the building shall be deemed to be projecting wall signs. Under-canopy signs which are parallel to the face of the building shall be a minimum of eight (8) feet above grade and shall be deemed to be flush wall signs.
  2. **Required maintenance.** Canopies shall be regularly cleaned and kept free of dust and visible defects.
- C. **Freestanding Signs.** A freestanding sign is a sign which is supported by one or more columns, uprights, poles or braces extended from the ground, or which is erected on the ground and shall also include a monument sign and pole signs but does not include a sign attached to a structure.
1. **Location.** The sign may be located only on a site frontage adjoining a public street. No freestanding sign in any zoning/sign district can be erected closer than eight (8) feet from any curblineline, nor closer than four (4) feet to any building. No freestanding signs in business and industrial districts may be located less than twenty-five (25) feet from any property line adjacent to a residential zoning district line.
  2. **Maximum area and height.** The sign shall comply with the height and area requirements

established in 17.18.130 Sign Matrices.

3. Sign mounting. The sign shall be mounted on one or more posts or have a solid monument-type base. Posts shall not have a diameter greater than twelve (12) inches. Pole bases shall be protected by concrete or a similar sturdy structure to prevent damage. Pole base structures may be used as landscaping planters.
4. Pole signs. Pole signs should not be so large as to obscure the patterns of front facades and yards.

D. **Monument Signs.** A monument sign is a permanent sign where the entire bottom of the sign is affixed to the ground, not to a building.

1. Location. The sign may be located only along a site frontage adjoining a public street.
2. Maximum area and height. The sign shall comply with the height and area requirements established in 17.18.130 Sign Matrices.
3. Design. The design of a monument sign shall be consistent with the overall scale of the building. The design and placement of the sign shall not obstruct traffic safety sight distance areas. Project monument signs shall contain only the name and address of the project which it identifies.
4. Landscaping requirements. Landscaping shall be provided at the base of the supporting structure equal to twice the area of one face of the sign. For example, twenty (20) square feet of sign area equals forty (40) square feet of landscaped area. The Planning Commission may reduce or waive this requirement if it is determined that the additional landscaping would not contribute significantly to the overall aesthetic character of the project.

E. **Projecting Signs.** A projecting sign is any sign supported by a building wall and projecting therefrom at least twelve (12) inches or more horizontally beyond the surface of the building to which the sign is attached, but shall not extend more than four (4) feet from the building face.

1. Location. Projecting signs shall be placed only on a ground floor facade, except for businesses located above the ground level with direct exterior pedestrian access. Projecting signs shall generally align with other projecting signs in the block to create a "canopy line" that gives scale to the sidewalk.
2. Maximum area and height. Projecting signs shall not be higher than the wall from which the sign projects if attached to a single story building, or the height of the bottom of any second story window if attached to a multi-story building. Projecting signs must have eight (8) feet clearance, and may not extend more than four (4) feet from the building wall except where the sign is an integral part of an approved canopy or awning. The size of projecting signs is limited to three (3) feet wide and six (6) square feet.
3. Sign structure. Sign supports and brackets shall be compatible with the design and scale of the sign.
4. Quantity. The number of projecting signs is limited to one per business.



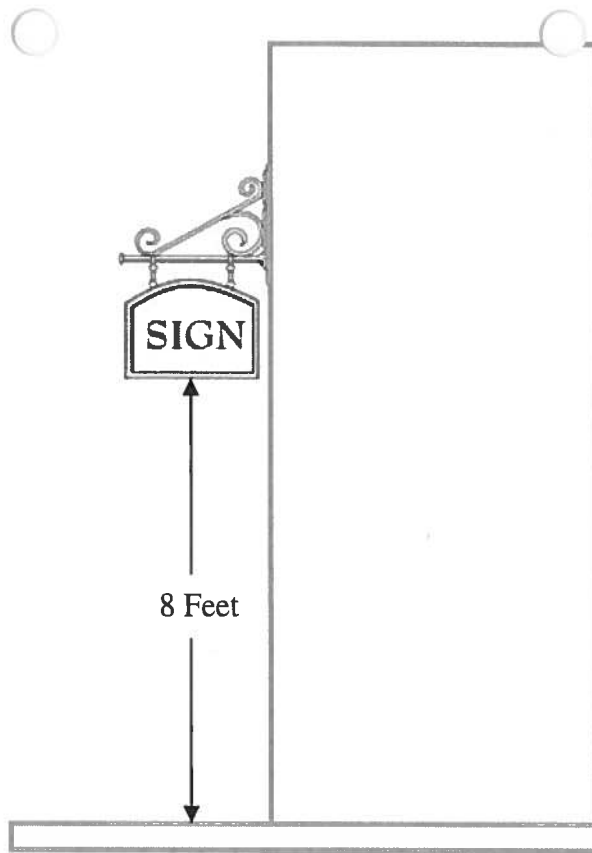

**Figure 7-10**

- F. **Standard Brand-Name Signs** A standard brand-name sign is any sign devoted to the advertising of any standard brand-name commodity or service which is not the principal commodity or service being sold or rendered on the premises, or are not a part of the name or business concern involved.
1. Maximum area. Not more than twenty (20) percent of the total allowable sign area for any permitted use shall be devoted to the advertising of any standard brand-name commodity or service.
- G. **Time and/or Temperature Signs.** A time and/or temperature sign is any sign intended to be displayed for a limited period of time and capable of being viewed from any public right-of-way, parking area or neighboring property.
1. Maximum area. Time and/or temperature signs which do not exceed ten (10) square feet shall not be required to be included in the allowable sign area permitted in 17.18.130 Sign Matrices; provided however, that any identification or advertising which is attached to or made part of the same sign structure shall be included in the allowable sign area for the premises.
  2. Design. The sign shall be designed in a manner that is compatible with other signs on the site and with the structure on which it is placed.
  3. Maintenance. It shall be the responsibility of the owner of such signs to maintain such signs and insure that they are kept accurate. If these conditions are not met, the sign shall be repaired or removed.
- H. **Wall Signs** A wall sign is any sign painted on, incorporated in or affixed to the building wall, or any sign consisting of cut-out letters or devices affixed to the building wall with no background defined on the building wall.
1. Location. The sign shall not be placed to obstruct any portion of a window, doorway or other architectural detail. Locate wall signs on buildings at the first floor level only for

retail uses. No part of a wall sign shall be located more than twenty-five (25) feet above grade level nor shall it extend above the building eave.

2. Maximum area and height. Wall signs shall not be higher than the eave line of the principal building. The sign shall comply with the height and area requirements established in 17.18.130 Sign Matrices.
3. Projection from wall. No sign part, including cut-out letters may project from the surface upon which it is attached more than required for construction purposes and in no case more than twelve (12) inches.
4. Design. Wall signs shall identify the individual business, building or building complex by name or trademark only.

I. **Window Signs** A window sign is a sign that is painted on, applied or attached to a window or that can be read through the window from the public right-of-way, placed at or below the second floor level.

1. Maximum area. When a sign is displayed in a window and is visible beyond the boundaries of the lot upon which the sign is displayed, the total area of such sign shall not exceed twenty-five (25) percent of the window or door area at the ground floor level; and twenty-five (25) percent of the total allowable sign area for the premises.
2. Lighting. All illuminated window signs shall be included in the total allowable sign area for the premises.
3. Temporary window signs. Temporary signs or posters displayed for periods not exceeding fourteen (14) days announcing or advertising events sponsored by noncommercial organizations shall be exempt from limitations for window signs.

#### 17.18.120 CREATIVE SIGNS

- A. **Purpose.** This Section establishes standards and procedures for the design, review and approval of creative signs. The purposes of this creative sign program are to:
  1. Encourage signs of unique design, and that exhibit a high degree of thoughtfulness, imagination, inventiveness, and spirit; and
  2. Provide a process for the application of sign regulations in ways that will allow creatively designed signs that make a positive visual contribution to the overall image of the Town of New Castle, while mitigating the impacts of large or unusually designed signs.
- B. **Applicability.** An applicant may request approval of a Sign Permit under the creative sign Program to authorize on-site signs that employ standards that differ from the other provisions of this Chapter but comply with the provisions of this Section.
- C. **Approval Authority.** A Sign Permit application for a creative sign shall be subject to approval by the Planning Commission.
- D. **Application Requirements.** A Sign Permit application for a creative sign shall include all information and materials required by the Town of New Castle, and the filing fee based on the same fee schedule as a building permit.
- E. **Design Criteria.** In approving an application for a creative sign, the Planning Commission shall ensure that a proposed sign meets the following design criteria:
  1. Design quality. The sign shall:
    - a. Constitute a substantial aesthetic improvement to the site and shall have a positive visual impact on the surrounding area;
    - b. Be of unique design, and exhibit a high degree of thoughtfulness, imagination, inventiveness, and spirit;

- c. Provide strong graphic character through the imaginative use of graphics, color, texture, quality materials, scale, and proportion.
2. Contextual criteria. The sign shall contain at least one (1) of the following elements:
  - a. Classic historic design style;
  - b. Creative image reflecting current or historic character of the Town of New Castle.
  - c. Symbols or imagery relating to the entertainment or design industry; or
  - d. Inventive representation of the use, name or logo of the structure or business.
3. Architectural criteria. The sign shall:
  - a. Utilize and/or enhance the architectural elements of the building.
  - b. Be placed in a logical location in relation to the overall composition of the building's façade.
  - c. Not cover any key architectural features/details of the facade.

**17.18.130 SIGN MATRICES**

The following section of these regulations corresponds to the following sign districts identified on the Sign District Map.

1. Residential District
2. Gateway District
3. Downtown & Mixed-Use District
4. Industrial District

This section includes a series of sign matrices that address permitted, exempt or prohibited signs, sign area, sign illumination and sign height. These tables are intended to assist the user in understanding the type, size, illumination and height of various signs in each sign district. This information is intended to be used in conjunction with the Sign District Map and other sections of these regulations.

**Sign Standards Matrix.**

<b>17.18.131 Permitted, Exempt or Prohibited Sign Type</b>	<b>Residential District</b>	<b>Gateway District</b>	<b>Downtown &amp; Mixed-Use District</b>	<b>Industrial District</b>
Awning Sign	Prohibited	Permitted	Permitted	Permitted
Banner	Prohibited	Permitted	Permitted	Permitted
Bulletin Board	Exempt	Exempt	Exempt	Exempt
Canopy Sign	Prohibited	Permitted	Permitted	Prohibited
Changeable Copy Sign	Prohibited	Permitted	Prohibited	Permitted
Creative Sign	Prohibited	Permitted	Permitted	Permitted
Directional Sign	Exempt	Exempt	Exempt	Exempt
Government Sign	Exempt	Exempt	Exempt	Exempt
Grand Opening Sign (Banner)	Prohibited	Permitted	Permitted	Permitted
Identification Sign	Permitted	Permitted	Permitted	Permitted
Incidental Sign	Prohibited	Permitted	Permitted	Permitted
Informational Sign	Prohibited	Exempt	Exempt	Exempt
Marquee Sign	Prohibited	Permitted	Permitted	Permitted
Monument Sign	Permitted	Permitted	Prohibited	Permitted
Nameplate	Exempt	Exempt	Exempt	Exempt
Off-Premises Sign	Permitted	Permitted	Permitted	Permitted
Painted Wall Sign	Prohibited	Permitted	Permitted	Permitted
Pole Sign	Prohibited	Permitted	Prohibited	Permitted
Political Sign	Exempt	Exempt	Exempt	Exempt
Portable Sign	Prohibited	Permitted	Permitted	Prohibited
Projecting Sign	Permitted	Permitted	Permitted	Permitted
Real Estate Sign	Exempt	Exempt	Exempt	Exempt
Roof Sign	Prohibited	Prohibited	Prohibited	Prohibited
Subdivision Identification Sign	Permitted	Prohibited	Prohibited	Prohibited

<b>17.18.131 Permitted, Exempt or Prohibited Sign Type</b>	<b>Residential District</b>	<b>Gateway District</b>	<b>Downtown &amp; Mixed-Use District</b>	<b>Industrial District</b>
Suspended Sign	Permitted	Permitted	Permitted	Permitted
Temporary Sign	Permitted	Permitted	Permitted	Permitted
Wall Sign	Permitted	Permitted	Permitted	Permitted
Window Sign	Prohibited	Permitted	Permitted	Permitted

<b>17.18.132 Sign Area Matrix Sign Type</b>	<b>Residential District Sq Ft</b>	<b>Gateway District Sq Ft</b>	<b>Downtown &amp; Mixed-Use District Sq Ft</b>	<b>Industrial District Sq Ft</b>
Awning Sign	0	Sum of all signs on a given wall shall not exceed 5% of the side of the wall area, but shall not exceed 150 ft. <sup>2</sup> (a)	10 if main business sign; 4 if it is an auxiliary business sign	Sum of all signs on a given wall shall not exceed 5% of the side of the wall area, but shall not exceed 150 ft. <sup>2</sup> (a)
Banner	0	60	60	60
Bulletin Board	15	15	15	15
Canopy Sign	0	Sum of all signs on a given wall shall not exceed 5% of the side of the wall area, but shall not exceed 150 ft. <sup>2</sup> (a)	10 if main business sign; 4 if it is an auxiliary business sign	0
Changeable Copy Sign	0	15	15	15
Creative Sign	0	Sum of all signs on a given wall shall not exceed 5% of the side of the wall area, but shall not exceed 150 ft. <sup>2</sup> (a)	10 if main business sign; 4 if it is an auxiliary business sign	Sum of all signs on a given wall shall not exceed 5% of the side of the wall area, but shall not exceed 150 ft. <sup>2</sup> (a)
Directional Sign	4	4	4	4
Government Sign	Exempt	Exempt	Exempt	Exempt

<b>17.18.132 Sign Area Matrix Sign Type</b>	<b>Residential District Sq Ft</b>	<b>Gateway District Sq Ft</b>	<b>Downtown &amp; Mixed- Use District Sq Ft</b>	<b>Industrial District Sq Ft</b>
Grand Opening Sign (Banner)	0	32	32	32
Identification Sign	2	2	2	2
Incidental Sign	0	8	8	8
Informational Sign	0	4	4	4
Marquee Sign	0	See "Wall Sign"	See "Wall Sign"	See "Wall Sign"
Monument Sign	64(b)	120(c)	0	120(c)
Nameplate	2	2	2	2
Off-Premises Sign	4(d)	4(d)	4(d)	4(d)
Painted Wall Sign	0	See "Wall Sign"	See "Wall Sign"	See "Wall Sign"
Pole Sign	0	128(e)	0	128(e)
Political Sign	Exempt	Exempt	Exempt	Exempt
Portable Sign	0	4	4	0
Projecting Sign	6(g)	6(f)	6(f)	6(f)
Real Estate Sign	4	4	4	4
Roof Sign	0	0	0	0
Subdivision Identification Sign	64(b)	0	0	0
Suspended Sign	6(g)	6(f)	6(f)	6(f)
Temporary Sign	See Sign Code Text	See Sign Code Text	See Sign Code Text	See Sign Code Text
Wall Sign	6(g)	6(f)	6(f)	6(f)
Window Sign	0	25% window area (i)(j)	25% window area (i)(j)	25% window area (i)(j)

(a) Allowed in place of a wall sign & 1 per individual building tenant.

(b) Downward and direct illumination only; when placed on subdivision entry features, only the sign face shall be used to calculate the sign area.

(c) Minimum horizontal distance between signs on the same property is seventy-five (75) feet.

(d) Farm products, real estate & directional signs only. See applicable sign regulation sections.

- (e) In place of project monument sign; not allowed on local or collector streets. Minimum horizontal distance between signs on the same property is seventy-five (75) feet.
- (f) One (1) per individual tenant building frontage. The sum of all wall signs on a given wall shall not exceed 5% of the wall area, but shall not exceed 150 sq. ft.; cannot be more than 25' above grade level or higher than the eave line of the principal building; first floor level only for retail uses.
- (g) One (1) per street frontage, all signs may be no higher than the eave line of the principal building; may be lighted (shielded light source) and include name and address of facility only. Child Care Center & Bed and breakfast only.
- (h) Cannot exceed 25% of the total allowable sign area for the premises.
- (i) Illuminated window signs shall be included in the total allowable sign area for the premises.
- (j) Temporary signs or posters displayed for periods not exceeding fourteen (14) days announcing or advertising events sponsored by noncommercial organizations shall be exempt from limitations for window signs.

<b>17.18.133 Sign Illumination Matrix Sign Type</b>	<b>Residential District-Illumination Allowed Y/N</b>	<b>Gateway District-Illumination Allowed Y/N</b>	<b>Downtown &amp; Mixed-Use District-Illumination Allowed Y/N</b>	<b>Industrial District-Illumination Allowed Y/N</b>
Awning Sign	N	N	N	N
Banner	N	N	N	N
Bulletin Board	N	Y	Y	Y
Canopy Sign	N	N	N	N
Changeable Copy Sign	N	Y	N	Y
Creative Sign	N	N	N	N
Directional Sign	N	N	N	N
Government Sign	Exempt	Exempt	Exempt	Exempt
Grand Opening Sign (Banner)	N	N	N	N
Identification Sign	N	N	N	N
Incidental Sign	N	N	N	N
Informational Sign	N	N	N	N
Marquee Sign	N	Y	Y	Y

<b>17.18.133 Sign Illumination Matrix Sign Type</b>	<b>Residential District-Illumination Allowed Y/N</b>	<b>Gateway District-Illumination Allowed Y/N</b>	<b>Downtown &amp; Mixed-Use District-Illumination Allowed Y/N</b>	<b>Industrial District-Illumination Allowed Y/N</b>
Monument Sign	Y(a)	Y	N	Y
Nameplate	N	Y	Y	Y
Off-Premises Sign	N	N	N	N
Painted Wall Sign	N	Y	Y	Y
Pole Sign	N	Y	N	Y
Political Sign	N	N	N	N
Portable Sign	N	N	N	N
Projecting Sign	N	Y	Y	Y
Real Estate Sign	N	N	N	N
Roof Sign	N	N	N	N
Subdivision Identification Sign	N	N	N	N
Suspended Sign	Y(a)	Y	Y	Y
Temporary Sign	N	N	N	N
Wall Sign	Y(a)	Y	Y	Y
Window Sign	N	(b)	(b)	(b)

(a) Downward aimed direct light source only; may not be illuminated between 10 p.m. and 7 a.m. if within 500' of existing residential uses.

(b) Illuminated window signs shall be included in the total allowable sign area for the premises.

<b>17.18.134 Sign Height Matrix Sign Type</b>	<b>Residential District-Max Height-Feet</b>	<b>Gateway District-Max Height-Feet</b>	<b>Downtown &amp; Mixed-Use District-Max Height-Feet</b>	<b>Industrial District-Max Height-Feet</b>
Awning Sign	0	(a)	(a)	(a)
Banner	0	(a)	(a)	(a)



<b>17.18.134 Sign Height Matrix Sign Type</b>	<b>Residential District- Max Height-Feet</b>	<b>Gateway District-Max Height-Feet</b>	<b>Downtown &amp; Mixed-Use District-Max Height-Feet</b>	<b>Industrial District-Max Height-Feet</b>
Bulletin Board	6	6	6	6
Canopy Sign	0	(a)	(a)	0
Changeable Copy Sign	0	(a)	0	(a)
Creative Sign	0	4	4	4
Directional Sign	4	4	4	4
Government Sign	Exempt	Exempt	Exempt	Exempt
Grand Opening Sign (Banner)	0	(a)	(a)	(a)
Identification Sign	6(a)	6(a)	6(a)	6(a)
Incidental Sign	0	6(a)	6(a)	6(a)
Informational Sign	0	6(a)	6(a)	6(a)
Marquee Sign	0	(a)	(a)	(a)
Monument Sign	5	6	0	6
Nameplate	Exempt	6(a)	6(a)	6(a)
Off-Premises Sign	4	4	4	4
Painted Wall Sign	0	(a)	(a)	(a)
Pole Sign	0	25	0	25
Political Sign	Exempt	Exempt	Exempt	Exempt
Portable Sign	0	4	4	0
Projecting Sign	6	(b)	(b)	(b)
Real Estate Sign	4	4	4	4
Roof Sign	0	0	0	0
Subdivision Identification Sign	5	0	0	0
Suspended Sign	6	(b)	(b)	(b)
Temporary Sign	6	6	6	6

17.18.134 Sign Height Matrix Sign Type	Residential District- Max Height-Feet	Gateway District-Max Height-Feet	Downtown & Mixed-Use District-Max Height-Feet	Industrial District-Max Height-Feet
Wall Sign	6(a)	(c)	(c)	(c)
Window Sign	0	θ(d)	θ(d)	θ(d)

(a) May be no higher than the eave line of the principal building.

(b) Min. Height above sidewalk or grade 8'. Shall not be higher than the eave from which the sign projects if attached to a single story building or 15' above grade whichever is less or the height of the bottom of any second story window if attached to a multi-story building.

(c) Cannot be 25' above grade level or higher than the eave line of the principal building; first floor level only for retail uses

(d) Window signs visible beyond the boundaries of the lot upon which the sign is displayed shall not exceed twenty-five (25) percent of the window or door area at the ground floor level; and twenty-five (25) percent of the total allowable sign area for the premises.